

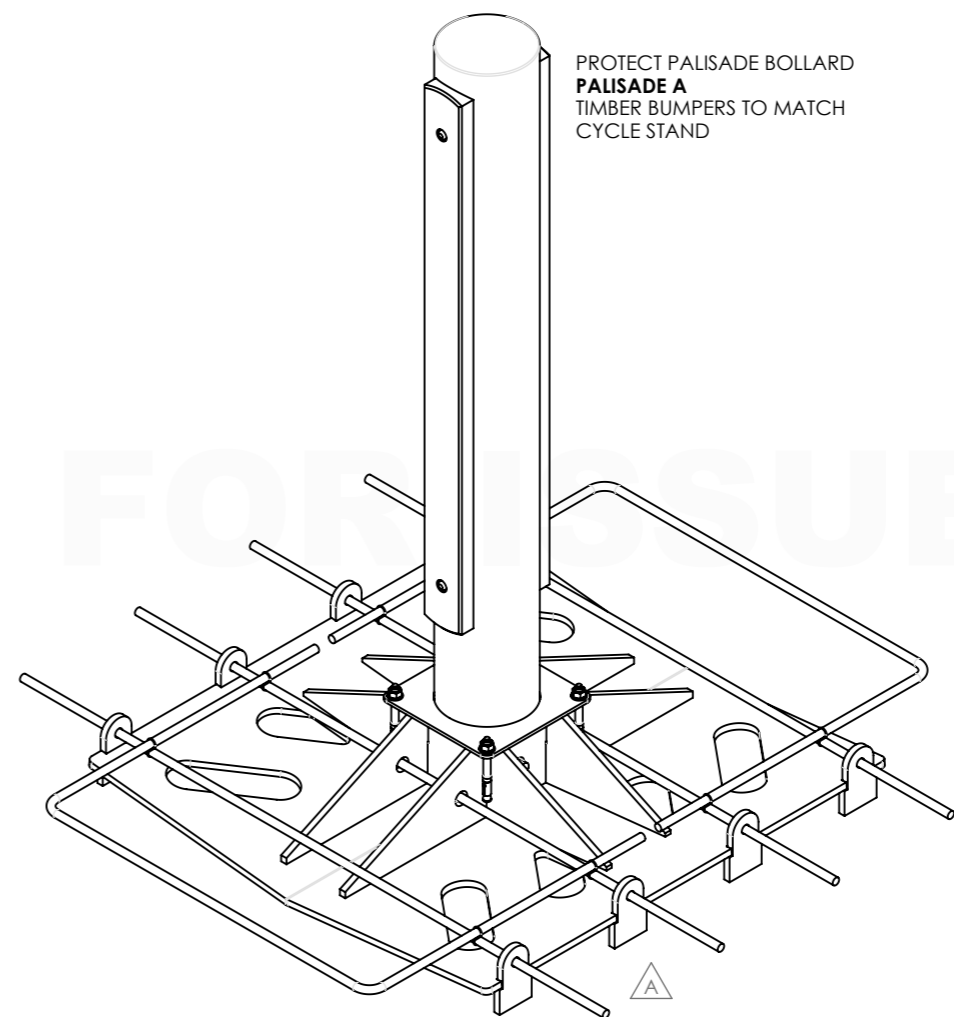

APPROVED FOR ISSUE



PROTECT PALISADE BOLLARD
PALISADE A
TIMBER BUMPERS TO MATCH
CYCLE STAND

PRODUCT OVERVIEW:
PROTECT PALISADE BOLLARD



Adlington Business Park, London Road, Adlington, Cheshire, SK10 4NL
Tel: 01625 322 888 | enquiries@bsfg.co.uk

DRAWING NUMBER: BSSGA2665-1_A	Doc. TYPE: GA	SHEET: SHEET 1 OF 3	SCALE: 1:10 @A3	DRW: OS	DATE: 07/09/2021
DRAWING TITLE: PRODUCT OVERVIEW - PROTECT PALISADE BOLLARD				CHK: JF	DATE: 07/09/2021
PART NUMBER: PROTECT PALISADE BOLLARD				APP: JF	DATE: 15/10/2021
PART CONFIGURATION: PALISADE A				DRAWING STATUS: APPROVED FOR ISSUE	
BSFG JOB NUMBER: STANDARD PRODUCT				Doc.REV: A	

DO NOT SCALE FROM DRAWING
DIMENSIONS IN mm UNLESS
STATED OTHERWISE

REVISIONS					
REV.	BY	DESCRIPTION	DATE	CHKD	APVD
A	OS	AMENDED CORE TO 1.5t	15/10/2021	JF	JF

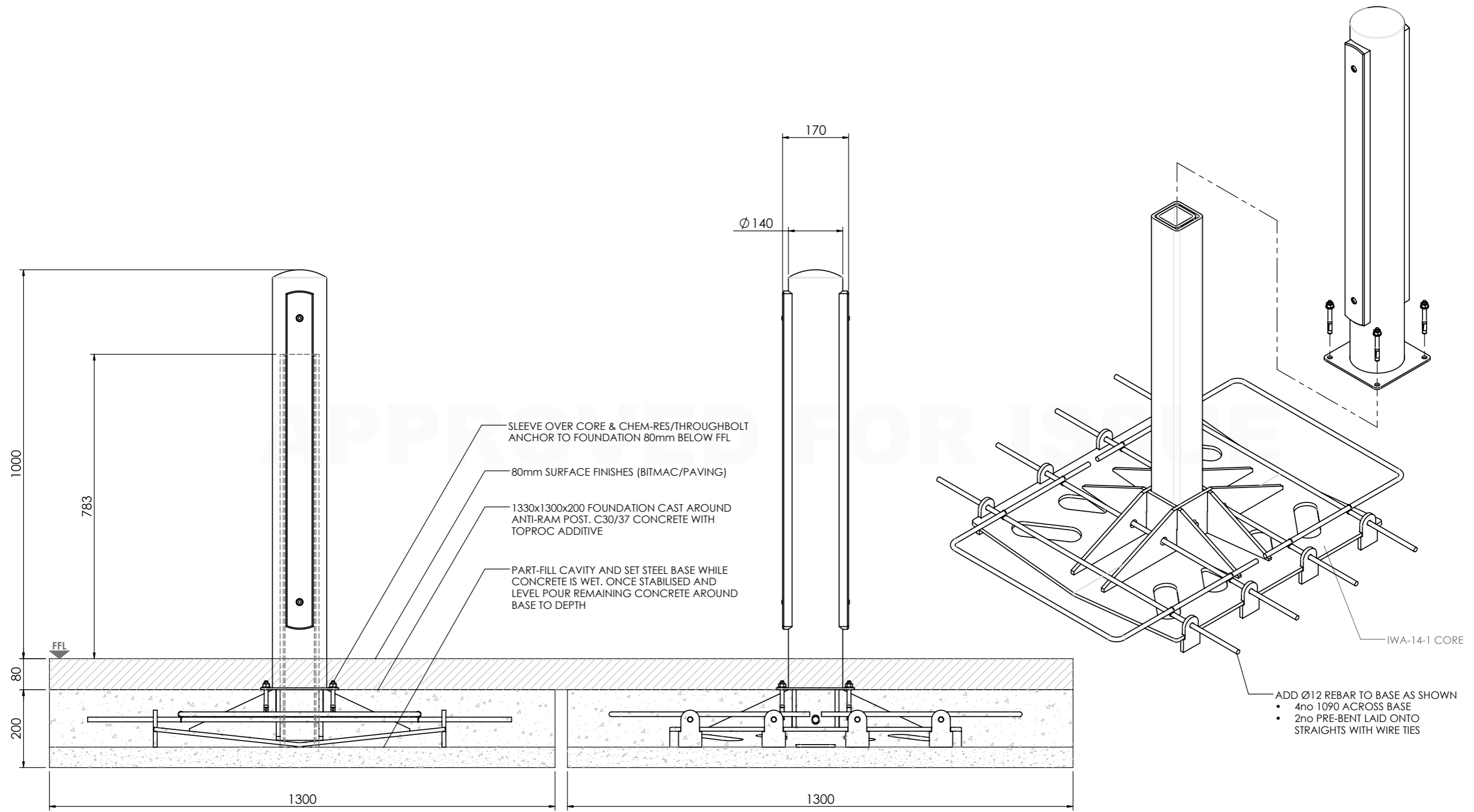

**GENERAL ARRANGEMENT:
PROTECT PALISADE BOLLARD**



Adlington Business Park, London Road, Adlington, Cheshire, SK10 4NL
Tel: 01625 322 888 | enquiries@bsfg.co.uk

DRAWING NUMBER: BSSGA2665-2_A	Doc. TYPE: GA	SHEET: SHEET 2 OF 3	SCALE: 1:10 @A3	DRW: OS	DATE: 07/09/2021
DRAWING TITLE: PROTECT ARRANGEMENT - PROTECT PALISADE BOLLARD				CHK: JF	DATE: 07/09/2021
PART NUMBER: PROTECT PALISADE BOLLARD				APP: JF	DATE: 15/10/2021
PART CONFIGURATION: PALISADE A				DRAWING STATUS: APPROVED FOR ISSUE	
BSFG JOB NUMBER: STANDARD PRODUCT		3rd ANGLE PROJECTION	DO NOT SCALE FROM DRAWING DIMENSIONS IN mm UNLESS STATED OTHERWISE	Doc.REV: A	

NOTES:
APPROXIMATE WEIGHT - 113.5kg

PRODUCTS WILL BE SUPPLIED WITH A SMALL IDENTIFICATION LABEL. IF YOU WOULD LIKE THIS REMOVED PRIOR TO DELIVERY PLEASE SPECIFY AT TIME OF ORDER

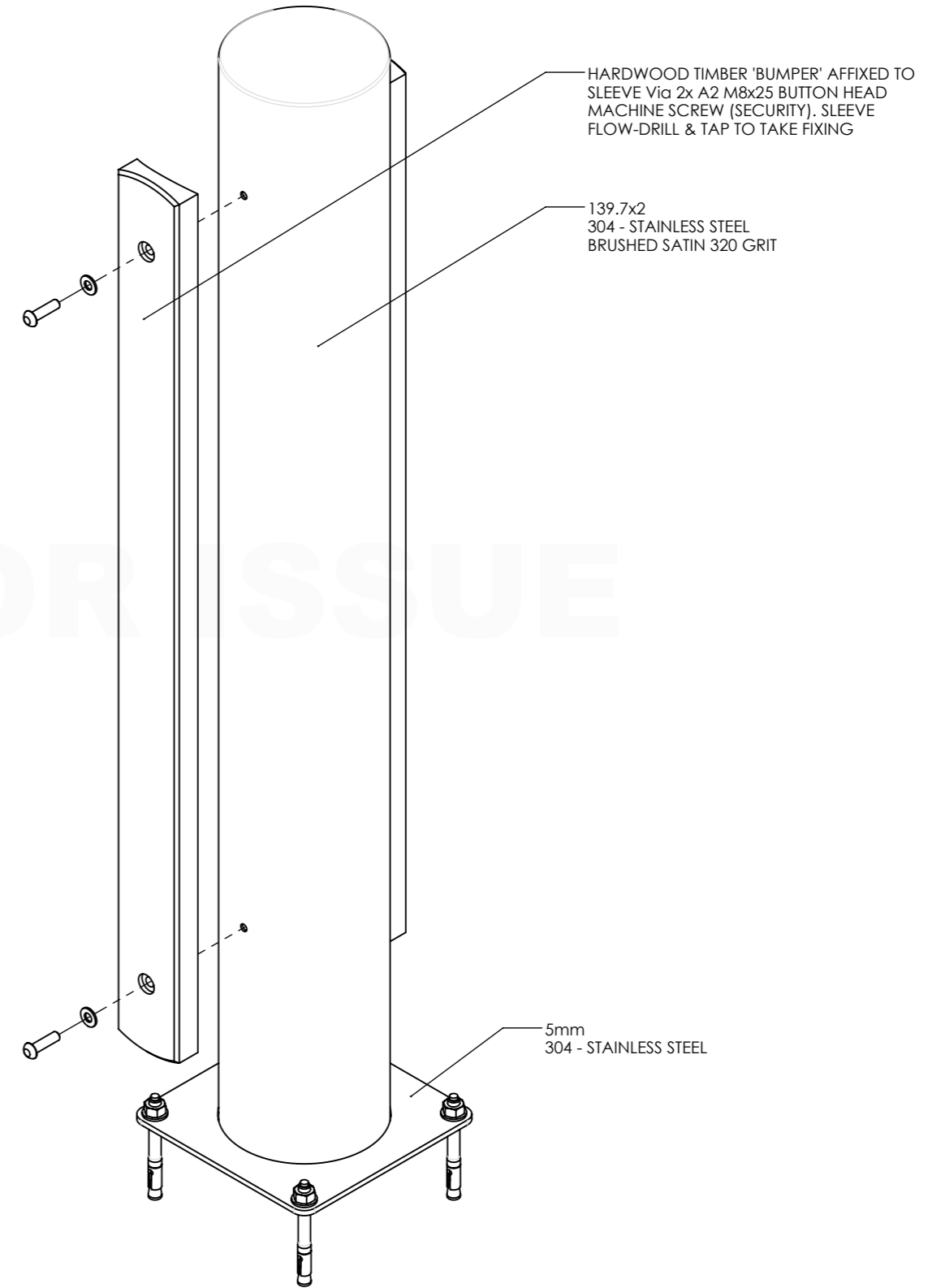
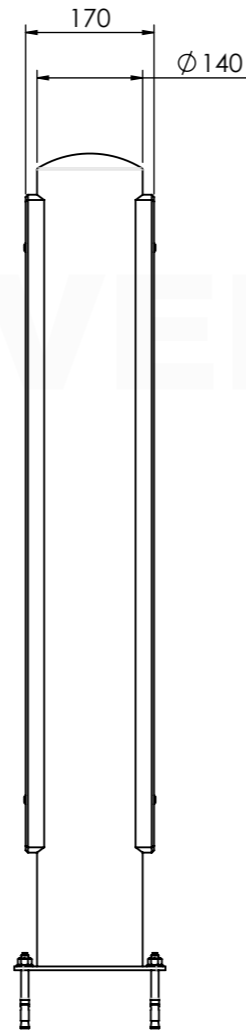
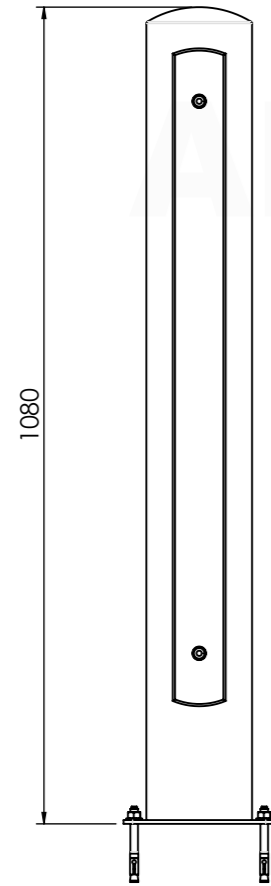
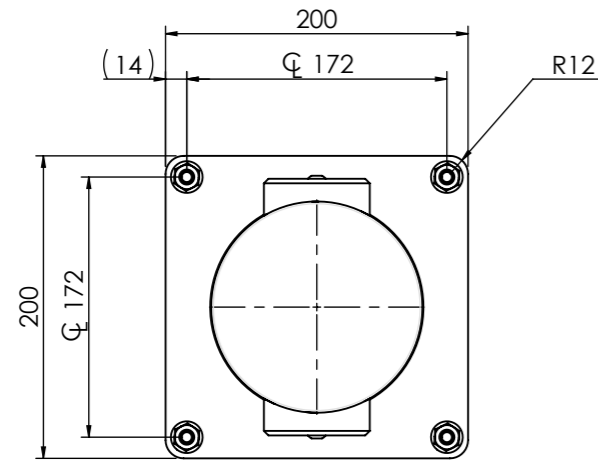

**GENERAL ARRANGEMENT:
PROTECT PALISADE BOLLARD**



Adlington Business Park, London Road, Adlington, Cheshire, SK10 4NL
Tel: 01625 322 888 | enquiries@bsfg.co.uk

DRAWING NUMBER: BSSGA2665-3_A	Doc. TYPE GA	SHEET: SHEET 3 OF 3	SCALE: 1:10 @A3	DRW: OS	DATE: 07/09/2021
DRAWING TITLE: GENERAL ARRANGEMENT - PROTECT PALISADE BOLLARD				CHK: JF	DATE: 07/09/2021
PART NUMBER: PROTECT PALISADE BOLLARD				APP: JF	DATE: 15/10/2021
PART CONFIGURATION: PALISADE A				DRAWING STATUS: APPROVED FOR ISSUE	
BSSFG JOB NUMBER: STANDARD PRODUCT		3rd ANGLE PROJECTION	DO NOT SCALE FROM DRAWING DIMENSIONS IN mm UNLESS STATED OTHERWISE	Doc.REV: A	

NOTES:
APPROXIMATE WEIGHT - 113.5kg

PRODUCTS WILL BE SUPPLIED WITH A SMALL IDENTIFICATION LABEL. IF YOU WOULD LIKE THIS REMOVED PRIOR TO DELIVERY PLEASE SPECIFY AT TIME OF ORDER